



Router Accessory Kit

TGA150

Operating and Safety Instructions



Thank you for purchasing this Triton tool. These instructions contain information necessary for safe and effective operation of this product.

Please read this manual to make sure you get the full benefit of its unique design.

Keep this manual close to hand and ensure all users of this tool have read and fully understand the instructions.

CONTENTS

Symbols	2
Parts List	3
Safety	4
Template Guide Bushes	5
Dust Chute	6
Table Winder	6
Warranty	7

SYMBOLS



Always wear ear, eye and respiratory protection.



Instruction warning.



Do not use before viewing and fully understanding the operating instructions

PARTS LIST

- A. Dust Chute
- B. Table winder handle
- C. Table Spacer
- D. ¼" x 1" Philips-head screw
- E. ¼" x ⅝" Philips-head screw
- F. Guide Plate to suit model TRA001 Routers
- G. ⅝" O.D. ⅝" I.D Guide Bush
- H. M4 Screws
- I. ⅝" O.D. ¼" I.D Guide Bush
- J. ⅜" O.D. ⅜" I.D Guide Bush
- K. ½" O.D. ⅜" I.D Guide Bush
- L. Guide Plate to suit model MOF001 Routers
- M. ⅞" O.D. ⅜" I.D Guide Bush
- N. ⅝" O.D. ⅜" I.D Guide Bush
- O. Alignment Bush (Porter Cable Adaptor)
- P. ¾" O.D. ⅜" I.D Guide Bush



GENERAL SAFETY INSTRUCTIONS



WARNING. Read all safety warnings and all instructions. Failure to follow the warnings and instructions may result in electric shock, fire and/or serious injury.

Save all warnings and instructions for future reference.

The term 'power tool' in the warnings refers to your mains-operated (corded) power tool or battery operated (cordless) power tool.

1. Work area safety

- a. Keep work area clean and well lit. Cluttered and dark areas invite accidents.
- b. Do not operate power tools in explosive atmospheres, such as in the presence of flammable liquids, gases or dust. Power tools create sparks which may ignite the dust or fumes.
- c. Keep children and bystanders away while operating a power tool. Distractions can cause you to lose control.

2. Electrical safety

- a. Power tool plugs must match the outlet. Never modify the plug in any way. Do not use any adaptor plug with earthed (grounded) power tools. Unmodified plugs and matching outlets will reduce risk of electric shock.
- b. Avoid body contact with earthed or grounded surfaces such as pipes, radiators, ranges and refrigerators. There is an increased risk of electric shock if your body is earthed or grounded.
- c. Do not expose power tools to rain or wet conditions. Water entering a power tool will increase the risk of electric shock.
- d. Do not abuse the cord. Never use the cord for carrying, pulling or unplugging the power tool. Keep the cord away from heat, oil, sharp edges or moving parts. Damaged or entangled cords increase the risk of electric shock.
- e. When operating a power tool outdoors, use an extension cord suitable for outdoor use. Use of a cord suitable for outdoor use reduces the risk of electric shock.
- f. If operating a power tool in a damp location is unavoidable, use a residual current device (RCD) protected supply. Use of an RCD reduces the risk of electric shock.

3. Personal safety

Do not use a power tool while you are tired or under the influence of drugs, alcohol or

medication. A moment of inattention while operating power tools may result in serious personal injury.

- a. Use safety equipment. Always wear eye protection. Safety equipment such as dust-mask, non-slip safety shoes, hard hat, or hearing protection used for appropriate conditions will reduce personal injuries.
- b. Avoid accidental starting. Ensure the switch is in the off position before plugging in. Carrying power tools with your finger on the switch or plugging in power tools that have the switch on invites accidents.
- c. Remove any adjusting key or wrench before turning the power tool on. A wrench or a key left attached to a rotating part of the power tool may result in personal injury.
- d. Do not overreach. Keep proper footing and balance at all times. This enables better control of the power tool in unexpected situations.
- e. Wear suitable clothing and footwear. Do not wear loose clothing or jewellery. Keep your hair, clothing and gloves away from moving parts. Loose clothes, jewellery or long hair can be caught in moving parts.
- f. If devices are provided for the connection of dust extraction and collection facilities, ensure these are connected and properly used. Use of these devices can reduce dust related hazards.

4. Power tool use and care

- a. Do not force the power tool. Use the correct power tool for your application. The correct power tool will do the job better and safer at the rate for which it was designed.
- b. Do not use the power tool if the switch does not turn it on and off. Any power tool that cannot be controlled with the switch is dangerous and must be repaired.
- c. Disconnect the plug from the power source before making any adjustments, changing accessories, or storing power tools. Such preventive safety measures reduce the risk of starting the power tool accidentally.
- d. Store idle power tools out of the reach of children and do not allow persons unfamiliar with the power tool or these instructions to operate the power tool. Power tools are dangerous in the hands of untrained users.

- e. Always unplug your power tool when leaving it unattended. Such preventative safety measures reduce the risk of starting the power tool accidentally by untrained users.
- f. Maintain power tools. Check for misalignment or binding of moving parts, breakage of parts and any other condition that may affect the operation of the power tool. If damaged, have the power tool repaired before use. Many accidents are caused by poorly maintained power tools.
- g. Keep cutting tools sharp and clean. Properly maintained cutting tools with sharp cutting edges are less likely to bind and are easier to control.

- h. Use the power tool, accessories and tool bits, in accordance with these instructions and in the manner intended for the particular type of power tool, taking into account the working conditions and the work to be performed. Use of the power tool for operations different from those intended could result in a hazardous situation.

5. Service

- a. Have your power tool serviced by a qualified repair person using only identical replacement parts. This will ensure that the safety of the power tool is maintained.

TEMPLATE GUIDE BUSHES

For template routing, using guide bushes on the Triton Router, the guide plate will first need to be fitted. There is a guide plate to suit both model Triton Routers - use the one specific to your model router.

1. With the router upside down, remove the black base via the 4 Phillips-headed screws.

MOF001 Models:

Fit the Guide Plate (L) to the underside of the black base and position it so that the key notches in the plate locate onto the tabs in the base.

TRB001 Models:

Position the Guide Plate (F) onto the router base with all the holes in the plate aligned with those in the router base.

2. Refit the base onto the router using the Phillips-headed screws. Do not tighten yet.

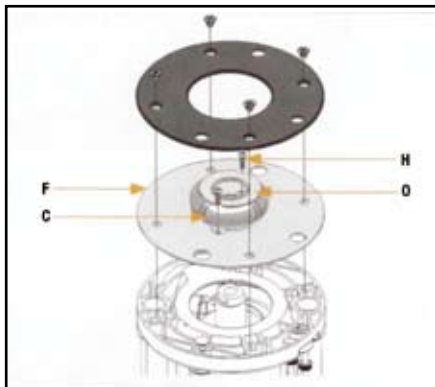

3. Loosely fit the two M4 Screws (H) into the holes in the depressed side of the adaptor plate, leaving a 3mm gap under each head. Sit the Alignment Bush (O) recessed side up, into the centre of the plate with the two notches positioned over the screw heads. Rotate the bush until the notches no longer align with the screw heads, then tighten the screws.
4. Plunge the router to the collet lock position, manoeuvring the black base so that the collet locates through the hole in the alignment bush. Tighten the 4 screws securing the black base in position. Do not overtighten as this can distort the plastic base.
5. Fit a router bit into the collet and plunge the router until the bit is hidden. remove the Alignment Bush and fit a Guide Bush (G, I, J, K, M, N & P) with its collar side up. Rotate the bit by hand to ensure there is complete clearance between the bit and the guide bush.

 If using a Porter Cable Guide Bush, fit it to the Alignment Bush first, with the guide bush fitting into the recessed side of the Alignment Bush. Then fit this assembly to the Guide Plate.

- Even when not using the template guides the guide plate can remain fitted to the router for the majority of cuts whether hand-held or table-mounted. If using cutters with a diameter larger than 50mm the guide plate will need to be removed.
- Regularly check that the M4 Screws (H) are tightened firmly. You may consider removing the screws and sorting them in the box when not using a guide bush.

GB

Table Mounted Use

The Spacer (C) is required when template routing on a Router Table. Remove the insert ring from your router table as it is not used with the template guide kit. Remove the screws from the Guide Plate and sit the spacer, recessed side up, into the centre of the plate. Align the screw holes then fit the screws and your chosen guide bush.

DUST CHUTE

The Dust Chute (A) can be fitted directly to the baseplate of the router if using a bearing guided cutter, or onto the extended baseplate (when fitted), for chip extraction beneath the cut.

1. Remove any two of the screws on the base of the router, depending on where you would like the dust chute located.

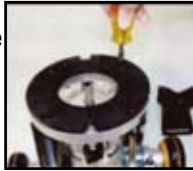

 Keep these screws in a safe place as they will need to be re-fitted when the dust chute is not in use.

2. Position the dust chute onto the base, with its slots aligned with the screw holes. Loosely fit the $\frac{5}{8}$ " Phillips-headed Screws (E), through the slots.



3. Slide the dust chute toward the cutter to best enclose the cut zone. Ensure that its positioning still enables you to achieve your desired cut. Tighten the screws.
4. Fit 38mm O.D. hose by screwing it on anti-clockwise.

 If using the extended baseplate, remove the two Phillips-head screws and then fit the extended baseplate to the router. The dust chute can then be fitted via the holes in the baseplate, using the 1" Phillips-headed Screws (D).



TABLE WINDER

1. Mount the router securely into your router table as detailed in your router table instructions. Turn the table (with router fitted) upside down.
2. With a marker pen trace the scallop in the base of the router onto the underneath of your router table. Complete the tracing to form a circle approximately $\frac{1}{2}$ " diameter.



3. Remove the router and drill a pilot hole through the centre of the circle. Using a $\frac{1}{2}$ " bit drill your final access hole.



 File off any rough burrs using a round file.

4. Refit the router and turn the router table right way up.
5. Fit the Table Winder Handle (B) through the hole in the tabletop and push it onto the routers winder mechanism.



 If necessary extend your hole using a round file.

6. Release the plunge lock lever and use the winder handle to set your cut depth.

Calibration marks:

Each line on the winder wheel represents 0.2mm cut depth increments. A full 360° turn is equal to a 2mm depth adjustment.

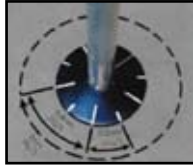

7. Re-lock the plunge lock lever and commence your work.

WARRANTY

To register your guarantee visit our web site at www.tritontools.com* and enter your details.

Your details will be included on our mailing list (unless indicated otherwise) for information on future releases. Details provided will not be made available to any third party.

PURCHASE RECORD

Date of Purchase: ___ / ___ / ___

Model: TGA150

Retain your receipt as proof of purchase

Triton Precision Power Tools guarantees to the purchaser of this product that if any part proves to be defective due to faulty materials or workmanship within 12 MONTHS from the date of original purchase, Triton will repair, or at its discretion replace, the faulty part free of charge.

This guarantee does not apply to commercial use nor does it extend to normal wear and tear or damage as a result of accident, abuse or misuse.

* Register online within 30 days.

Terms & conditions apply.

This does not affect your statutory rights.