

**triton** <sup>®</sup> *Mini Sliding Extension Table* ETA100

**Operating and  
Safety Instructions**



Thank you for purchasing this Triton product. These instructions contain information necessary for safe and effective operation of this product.

Please read this manual to make sure you get the full benefit of its unique design.

Keep this manual close to hand and ensure all users of this product have read and fully understand the instructions.

## CONTENTS

<b>Symbols</b>	2
<b>Parts list</b>	2
<b>Safety</b>	7
<b>Assembly</b>	6
<b>Operating</b>	7
<b>Angle settings</b>	9
<b>Guarantee</b>	9

## SYMBOLS



Always wear ear, eye and respiratory protection.



Conforms to relevant legislation and safety standards.



Instruction warning.



Do not use before viewing and understanding the full operating instructions

## PARTS LIST

### Table Assembly

1. Long Extrusions (2)
2. Short Extrusion Assemblies (2)
3. Scales (2)
4. Brace (1)
5. Corner Brackets (4)
6. Inner Bearings (smaller) (2)
7. Outer Bearings (larger) (2)
8. Fence Assembly (1)

### Fastener Bag 1

9. Brace Brackets (2)
10. Flange Nuts M6 (8)
11. Hex Bolts M6 x 10 (14)
12. Hex Nuts M6 (6)
13. Washers M6 (14)
14. Screws M6 x 16 (4)
15. Fence Bolts with square plastic feet (15)
16. Fence Sliders (2)
17. Round Knobs with Nut (2)

### Outer Track Assembly

18. Outer Track (1)
19. Legs (2)
20. Feet (2)
21. Leg Plates (4)
22. Leg Clamp Assemblies (2)

### Fastener Bag 2

17. Round Knobs with Nut (2)
23. Hex Bolts M6 x 40 (6)
24. Nyloc Nuts M6 (6)
25. Screws M4 x 10 (4)
26. Square Nuts M4 (4)
27. Height Stops (2)
28. Coach Bolts M6 x 20 (2)
29. Angled Tube Closers (2)
30. Flat Tube Closers (4)

### Fastener Bag 4

13. Washers M6 (4)
24. Nyloc Nuts M6 (4)
31. Shims (2)
32. Coach Bolts M6 x 50 (4)

### Inner Track Assembly

33. Inner Track (1)
34. Support Brackets (2)
35. Skid Assemblies (2)
36. Front Panel Bracket (1)
37. Rear Panel Bracket (1)
38. TCA/RSA Brackets (2)
39. Spacer Blocks (2)

### Fastener Bag 3

10. Flange Nuts M6 (2)
13. Washers M6 (4)
17. Round Knobs with nut (2)
24. Nyloc Nuts M6 (6)
28. Coach Bolts M6 x 20 (2)
40. Coach Bolts M6 x 12 (4)
41. Locking Latches (2)
42. Hex Bolts M6 x 45 (2)
43. Screws M6 x 10 (2)



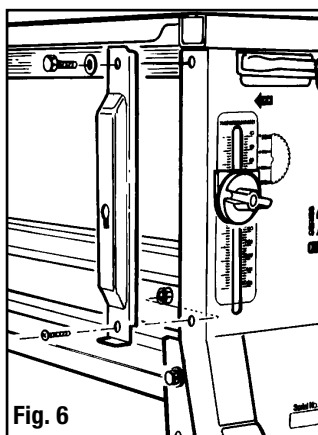

Fig. 6

Fig. 7

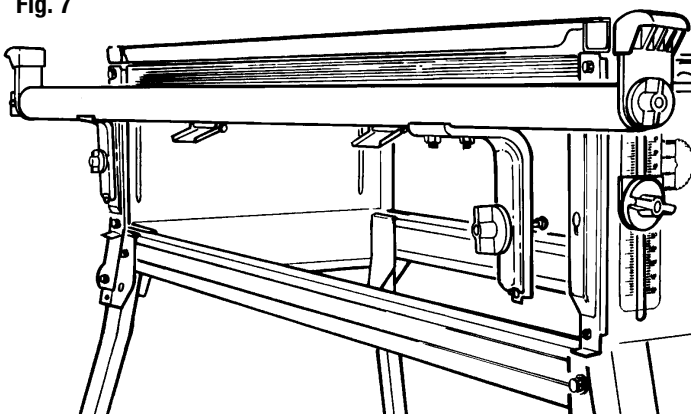

Fig. 8  
Compact Saw Table

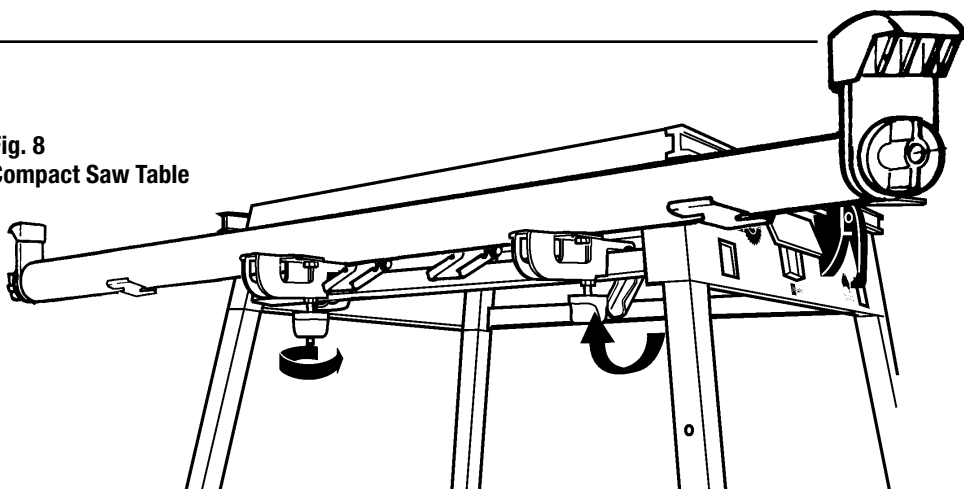
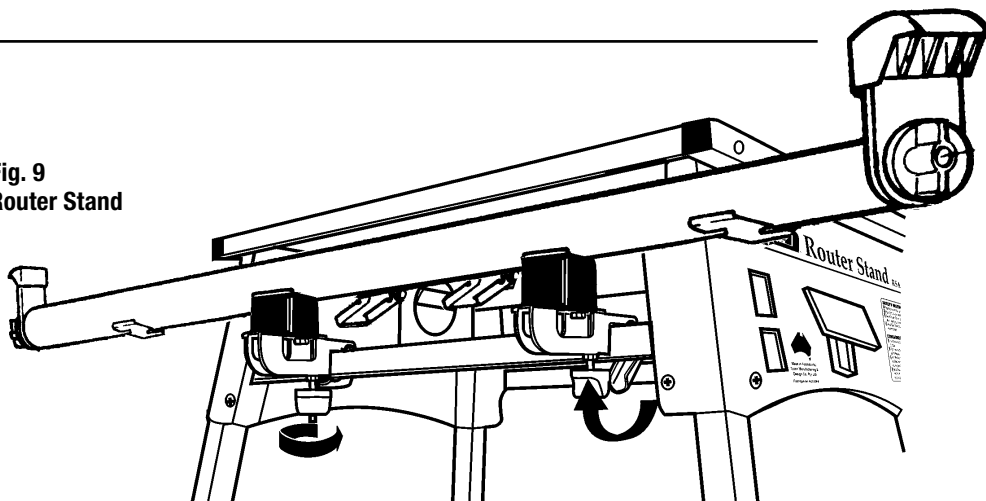
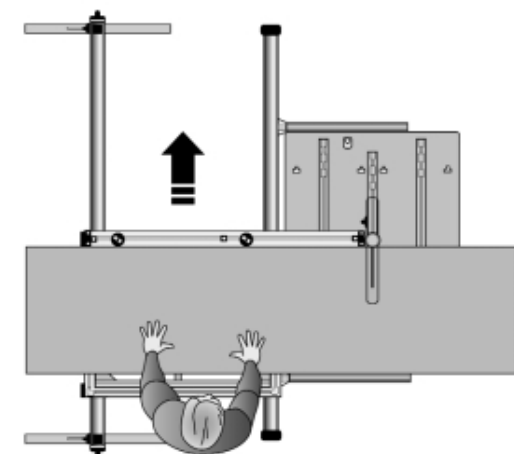
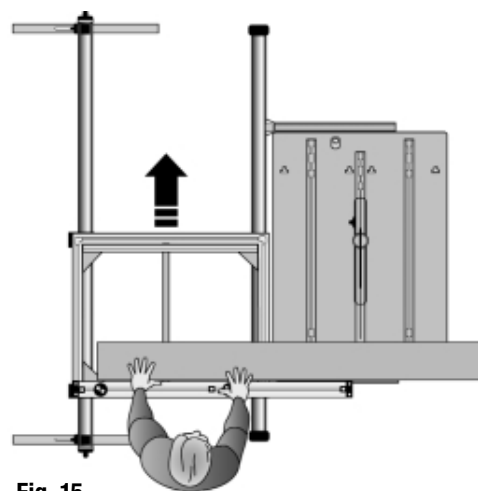
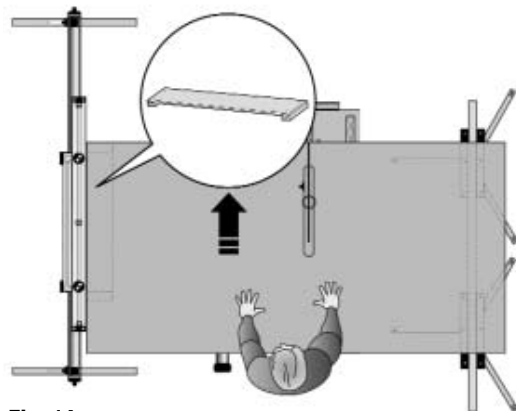
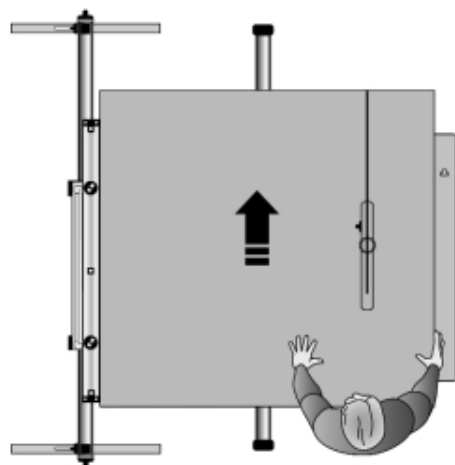
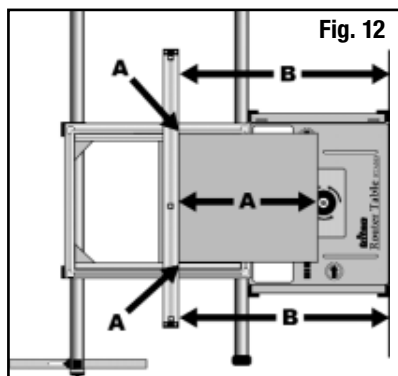
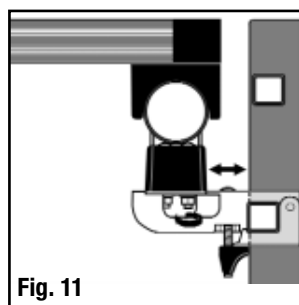
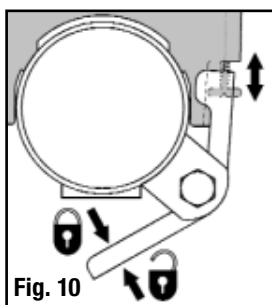

Fig. 9  
Router Stand





GB

Fig. 15

Fig. 16

Fig. 17

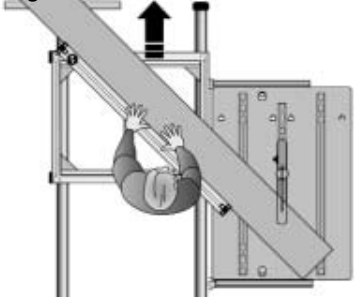

Fig. 18

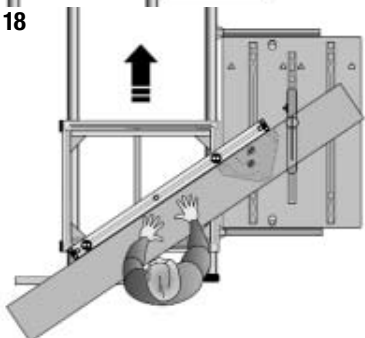

Fig. 21

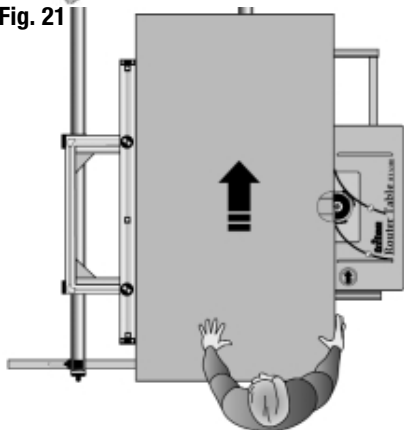

Fig. 22

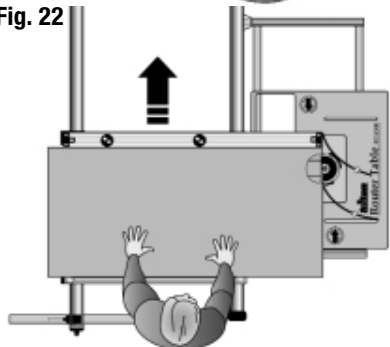

Fig. 19

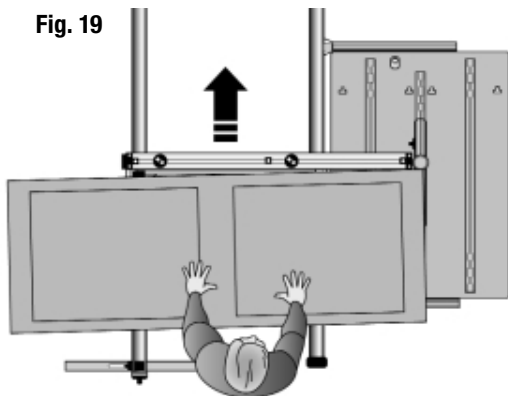

Fig. 20

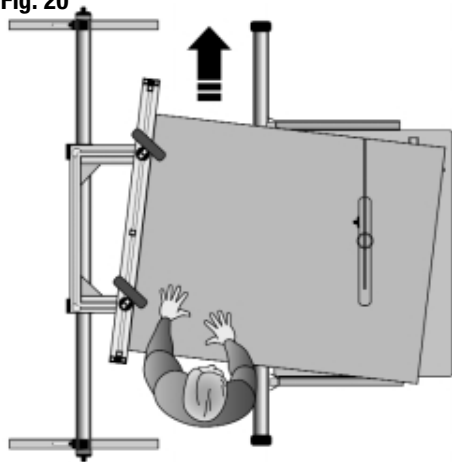
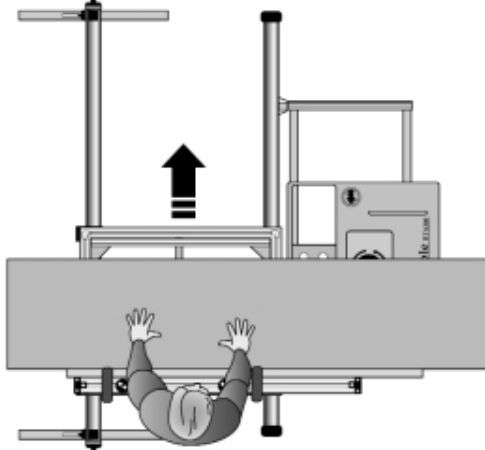



Fig. 23



## SAFETY INSTRUCTIONS

 **WARNING.** Read all instructions. Read all safety warnings and all instructions. Failure to follow the warnings and instructions may result in electric shock, fire and/or serious injury.

Save these instructions

### 1. WORK AREA SAFETY

a. Keep work area clean and well lit. Cluttered and dark areas invite accidents. b. Do not operate power tools in explosive atmospheres, such as in the presence of flammable liquids, gases or dust. Power tools create sparks which may ignite the dust or fumes. c. Keep children and bystanders away while operating a power tool. Distractions can cause loss of control.

### 2. ELECTRICAL SAFETY

- a. Power tool plugs must match the outlet. Never modify the plug in any way. Do not use any adapter plugs with earthed (grounded) power tools. Unmodified plugs and matching outlets will reduce risk of electric shock.
- b. Avoid body contact with earthed or grounded surfaces such as pipes, radiators, ranges and refrigerators. There is an increased risk of electric shock if your body is earthed or grounded.
- c. Do not expose power tools to rain or wet conditions. Water entering a power tool will increase the risk of electric shock.
- d. Do not abuse the cord. Never use the cord for carrying, pulling or unplugging the power tool. Keep the cord away from heat, oil, sharp edges or moving parts. Damaged or entangled cords increase the risk of electric shock.
- e. When operating a power tool outdoors, use an extension cord suitable for outdoor use, this will reduce the risk of electric shock.
- f. If operating a power tool in a damp location is unavoidable, use a residual current device (RCD) protected supply, which will reduce the risk of electric shock.

### 3. PERSONAL SAFETY

- a. Do not use power tools while you are tired or under the influence of drugs, alcohol or medication. A moment of inattention while operating power tools may result in serious personal injury.
- b. Always use safety equipment: wearing eye protection, dust mask, non-slip safety shoes,

hard hat and hearing protection used in appropriate conditions will reduce personal injuries.

- c. Avoid accidental starting. Ensure the switch is in the 'Off' position before plugging in. Carrying power tools with your finger on the switch or connecting to power with the switch on the 'On' position invites accidents.
- d. Remove any adjusting key or wrench before turning the power tool on. A wrench or a key left attached to a rotating part of the power tool may result in personal injury.
- e. Do not over-reach. Keep proper footing and balance at all times. This enables better control of the power tool in unexpected situations.
- f. Wear suitable clothing and footwear. Do not wear loose clothing, neckties, jewellery, or other items which may become caught. Wear non-slip footwear or where appropriate, footwear with protective toe caps. Long hair should be covered or tied back.
- g. If devices are provided for the collection of dust particles, ensure these are connected and properly used. Use of these devices can reduce dust related hazards.

### 4. POWER TOOL USE AND CARE

- a. Do not force the power tool. Using the correct power tool for your application will be safer and produce better results at the rate for which it was designed.
- b. Do not use the power tool if the 'On/Off' switch is not working correctly. Power tools that cannot be controlled by the switch are dangerous and must be repaired prior to use.
- c. Disconnect the plug from the power source before making any adjustments, changing accessories or storing power tools. Such preventive safety measures reduce the risk of starting the power tool accidentally.
- d. Power tools are dangerous in the hands of untrained users. Store power tools out of reach of children, and do not allow persons who are unfamiliar with the product or these instructions to operate the power tool.
- e. Maintain power tools. Check for misalignment, binding or breakage of moving parts, and any other condition that may affect the operation of the power tool. If damaged, have the power tool

GB

repaired before use. Accidents are caused by poorly maintained power tools.

- f. Keep cutting tools sharp and clean. Properly maintained cutting tools with sharp cutting edges are less likely to bind and are easier to control.
- g. Use the power tool, accessories and tool bits in accordance with these instructions and in the manner intended for the particular type of power tool, taking into account the working conditions and the work to be performed. Failure to use the tool for its intended purposes could result in a hazardous situation and may invalidate the warranty.

## 5. SERVICE

- a. Have your power tool serviced by a qualified repair technician, using only identical replacement parts. This will ensure that the safety of the power tool is maintained.

**NOTE:** The tool must be used only for its prescribed purpose. Any use other than those mentioned in this manual will be considered a case of misuse. The user and not the manufacturer shall be liable for any damage or injury resulting from such cases of misuse. To use this tool properly observe the safety regulations, assembly instructions and operating instructions, which can be found in this manual. All persons who use and service the machine must be informed about its potential hazards and be acquainted with this Manual. Children and frail people must not use this tool. Children should be supervised at all times if they are in the area in which the tool is being used. It is also imperative that you observe the accident prevention regulations in force in your area. The same applies for general rules of occupational health and safety. The manufacturer shall not be liable for any changes made to the tool nor for any damage resulting from such changes. Even when the tool is used as prescribed it is not possible to eliminate all residual risk factors.

## ASSEMBLY

### ASSEMBLING THE TABLE & RIP FENCE

#### STEP 1

Using the fasteners from Fastener Bag 1, insert 4 Flange Nuts (10) into each Long Extrusion (1) as shown in Inset 1 on (Fig. 1).

Lay out the two long extrusions and the two short extrusions as shown, making sure that all of the flange nuts are facing inwards.

Plug the corner blocks of the Short Extrusion Assemblies (2) into the ends of the long extrusions and tap fully home with a rubber mallet (or similar).

#### STEP 2

Turn the table over (face down) on a flat surface and loosely attach the Corner Brackets (5), using the Hex Bolts (11) and Washers (13) into the flange nuts. (Slide the flange nuts into position using a screwdriver).

Ensure that the two printed corner brackets are bolted with their correct edges on the same long extrusion, as illustrated on the brackets.

Loosely fit the Brace Brackets (9) to the Brace (4) using Hex Bolts (11), Washers (13) and Hex Nuts (12). See Inset 2 on (Fig. 1).

Position the brace centrally between the short extrusions, as shown, and loosely attach it with hex bolts and washers into the remaining flange nuts. Do not tighten any of the fasteners yet.

#### STEP 3

Turn the table face upwards again and insert the Scales (3) between the long extrusions and the brace and corner brackets. Position them with the 14¾" ends hard up against the short extrusion on the 'map of Australia' side of the table. Push the scales down until they 'click' into location, flush with the top face of the long extrusions, as shown in Inset 3 on (Fig. 1).

Turn the table over again (face down). Make sure the corner brackets are pushed fully into the corners, and that the plastic corner blocks are still fully inserted into the ends of the extrusions.

Tighten the 8 bolts holding the corner brackets. Do not over-tighten. (Tighten each pair of bolts a little at a time, to ensure you don't distort the frame).

Next tighten the 4 bolts holding the brace bracket to the long extrusion, and finally tighten the bolts in the brace.

#### STEP 4

Plug the two smaller Inner Bearings (6) into the corner blocks below the low scale readings and tighten using the Countersunk Screws (14) and Hex Nuts (12). The two longer Outer Bearings (7) are fitted to the corner blocks near the high scale readings.

#### STEP 5

Assemble the Fence Bolt (15), Fence Slider (16), and Round Knob (17) through the Fence (8), as shown.

With the round knobs loosened, lower the square feet of the fence bolts into the corner blocks as shown. Slide the fence along the extrusions to position it wherever you like, and test the clamping action. If necessary, spray the inside of the fence with a spray lubricant, such as RP7 or WD40, to improve the fence sliding action.

### ASSEMBLING THE OUTER TRACK

#### STEP 6

Insert the Coach Bolts (28) through the slots in the Legs (19), and fit the Height Stops (27) and Round Knobs (17) onto them, as shown in (Fig. 2).

Attach the Feet (20) to the legs using the Leg Plates (21), Hex Bolts (23) and Nyloc Nuts (24) as shown. Note: the raised bumps on the leg plates must face inwards, touching the legs. The feet should face away from the leg slots as shown.

Do not over-tighten the bolt which passes through each leg. The foot is designed to swing around on this bolt for easy storage.

#### STEP 7

Tap the Angled Tube Closers (29) into the bottoms of the legs ensuring they are correctly oriented, as shown. Tap the Flat Tube Closers (30) into the remaining tube ends, as shown.

#### STEP 8

Loosely fit the Phillips Screws (43) and Square Nuts (26) through the holes in each Clamp Assembly (22) as shown. Tap the assemblies onto the ends of the Outer Track (18) locating the screws in the notches, and tighten.

Loosen the large round knobs and align the cut-outs in the clamps with the square cut-outs in the track. Insert the legs through the cut-outs and tighten the

large round knobs to clamp. Slide the height stops up the leg slots until they touch the outer track and tighten into position. They help set the correct height for future set ups, and serve as protection against track slippage under heavy load.

### ASSEMBLING THE INNER TRACK

#### STEP 9

Undo the large round knob (one turn only) on each Skid Assembly (35) and insert them into the ends of the Inner Track (33). With the skids pointing up as shown, firmly tighten the knobs. (Figs. 3, 4 and 5).

Fasten the two Locking Latches (41) onto the latch brackets using the Hex Bolts (42) and Nyloc Nuts (24). Ensure the rectangular windows in the latches are oriented as shown in (Figs. 3, 4 and 5). Tighten the bolts until the latches pivot firmly.

**If you are fitting this product to a Workcentre, follow Steps 10W to 15W, for a Compact Saw Table use Steps 10C to 15C and for a Router Stand use Steps 10R to 15R.**

### FITTING TO A WORKCENTRE

#### STEP 10W

Loosely bolt the Support Brackets (34) to the two outer brackets on the Inner Track (33) using the short Coach Bolts (40), Washers (13) and Nyloc Nuts (12), as shown in Fig. 3. Do not tighten yet. Note the orientation of the brackets in regard to the long overhang of the inner track (marked 'X' in Fig. 7).

Loosely fasten the longer Coach Bolts (28) and Round Knobs (17) onto the support brackets.

#### STEP 11W

Fit the End Panel Brackets (36) and (37) to the left-hand side of the Workcentre (when viewed from the front panel, which has the switchbox). The brackets are left or right-handed the long edge flanges should wrap around the faces of the end panels. See Fig. 6.

At the top of each bracket, use the bolt, washer and nut which hold the left-hand bearing channel in position. At the bottom of each bracket, fit the Phillips Screw (43) and flange nut (10), but do not tighten yet.

Note: if you have a MK3 Workcentre or an early Series 2000 Workcentre (pre-serial no. 305000) it will be necessary to drill the lower holes through the

end panel flanges. Use the brackets as a drill guide, centre punching the hole positions toward the top of the slotted hole in the bracket. Drill 6.5mm or ¼" holes.

Fit the inner track to the Workcentre by locating the coach bolt heads through the keyholes in the end panel brackets. Make sure that the tabs on the bottom of the support brackets engage into the slots on the end panel brackets. Tighten the round knobs and then temporarily tighten the four nyloc nuts (24) holding the inner track to the brackets. Fig. 7

## Aligning the Tracks on a Workcentre

### STEP 12W

On Series 2000 Workcentres, push the legs diagonally outwards to ensure it is fully stable.

Position the outer track parallel to the inner track approximately 28" away from it. Place the table onto the tracks with the inner (smaller) bearings on the inner track. Always fit the table this way. Slide the table to each end of its travel and adjust the position of the outer track. The lengthened outer bearings make this a non-critical adjustment.

### STEP 13W

Next it will be necessary to fine-tune the height of the inner track. Fit the extension table fence to the sliding table and extend it across the Workcentre table. Loosen the bolts and screws attaching the end panel bracket, adjust the height of the brackets until the bottom of the fence is around ⅓" above the Workcentre table, front and rear. Tighten the bolts and Phillips screws holding the brackets to the end panels.

### STEP 14W

Next, adjust the height of the outer track until the fence is level across the Workcentre table.

Check the sliding table throughout its travel for diagonal rocking on the tracks, and fine tune the height of the outer track if necessary. Adjust the height stops on the outer track legs to lock-in the correct height.

With the sliding table positioned midway along the tracks, engage the front and rear locking latches (Fig.10). Adjust the self-tapping screws on the inner bearings until the heads enter the rectangular windows and the table cannot be lifted. (It will be

necessary to unlock the latches and lift the table clear to make these adjustments).

### STEP 15W

The last step is to fine-tune the inner track position in the horizontal plane, to ensure that the extension table scales are accurate.

**Series 2000 Workcentres:** With the extension table fitted and locked, and the rip fence removed, insert the standard Workcentre rip fence and set it to 16" using the end panel calibration marks. Prior to sighting down the front face of the Workcentre rip fence, loosen the four nyloc nuts on the inner track support brackets. Adjust the inner track sideways until both front and rear scales read exactly 16". Retighten the four nuts and remove the Workcentre rip fence.

**MK3 Workcentres:** Extend the extension table fence across the Workcentre until the tip is level with the left-hand edge of the saw slot. Check for parallel by sliding the extension table so that the fence tip runs the length of the saw slot. Loosen the four nyloc nuts on the inner track support brackets and adjust the position of the track until the fence tip aligns perfectly with the saw slot at both ends of the table travel.

To ensure the correct scale reading, position the extension table with the front scale level with the front of the saw blade and measure from the blade teeth to check the scale reading. Adjust the position of the inner track if necessary until the scales are accurate, ensuring the track is moved by exactly the same amount at each end.

Finally, double check the parallel alignment and scale accuracy by repeating the above steps, or by making a test cut.

Your Sliding Extension Table is now fully assembled and ready for use. Skip to the 'Operating' section.

## FITTING TO A COMPACT SAW TABLE

### STEP 10C

Loosely tighten the TCA/RSA Brackets (38) onto the two inside brackets on the Inner Track using the short Coach Bolts (40), Washers (13) and Nyloc Nuts (24) with a 10mm spanner, as shown in Fig. 4. Note the orientation of the brackets in regard to the long overhang of the inner track (marked "X" in Fig. 8).

## STEP 11C

Fit the inner track to the left side of the Compact (when viewed from the switch-box end) by locating the brackets over the square tube, as shown in (Fig. 8). Close the jaw of the bracket around the tube and tighten the clamp knobs until they hold the jaw firmly closed, front and rear. To remove the track loosen the clamp knobs half a turn until the flat faces of the knobs allow the jaws to swing open.

## Aligning the Tracks on a Compact Table

### STEP 12C

Position the outer track parallel to the inner track approximately 28" apart. Place the table onto the tracks with the inner (smaller) bearings on the inner track. Always fit the table this way. Slide the table to each end of its travel and adjust the position of the outer track. The lengthened outer bearings make this a non-critical adjustment.

### STEP 13C

Adjust the height of the outer track until the fence is level, and parallel to the Compact table.

Check the sliding table throughout its travel for diagonal rocking on the tracks, and fine tune the height of the outer track if necessary. Adjust the height stops on the outer track legs to lock-in the correct height.

Next it will be necessary to fine-tune the height of the inner track. Fit the extension table fence to the sliding table and extend it across the Compact table. The fence should sit around  $\frac{1}{2}$ " above the Compact. Slide the table to the rear of the Compact and check that it is level throughout the travel range. If necessary remove the inner track from the track clamp and insert one or both Shims (31) between the front and/or rear clamp and track. Loosely re-fit the bolts and nuts.

### STEP 14C

With the sliding table positioned midway along the Compact, engage the front and rear locking latches (Fig. 10). Adjust the self-tapping screws on the inner bearings until the heads enter the rectangular windows and the table cannot be lifted. (It will be necessary to unlock the latches and lift the table clear to make these adjustments).

## STEP 15C

The last step is to fine-tune the inner track position in the horizontal plane, to ensure that the extension table scales are accurate.

With the extension table fitted and locked, and the fence removed, insert the Compact rip fence and set it to 16" using the Compact scale pointers. Adjust the inner track sideways until both front and rear scales read exactly 16", (Fig. 11), when sighting down the face of the Compact rip fence. Tighten the Nyloc nuts then remove the Compact rip fence.

Your Sliding Extension Table is now fully assembled and ready for use. Skip to the 'Operating' section.

## FITTING TO A ROUTER STAND

### STEP 10R

Loosely fit the TCA/RSA Brackets (38), Spacer Blocks (39) and Shims (31) onto the two inside brackets on the Inner Track using the M6 x 50 Coach Bolts (32), Washers (13) and Nyloc Nuts (24), as shown. (Fig. 5). Note the orientation of the brackets in regard to the long and short overhang of the inner track.

### STEP 11R

Fit the inner track to the left side of the Router Stand (when viewed from the switch-box end) by locating the brackets over the square tube, as shown in (Fig. 9). Close the jaw of the bracket around the tube and tighten the clamp knobs until they hold the jaw firmly closed, front and rear. To remove the track loosen the clamp knobs half a turn until the flat faces of the knobs allow the jaws to swing open.

## Aligning the Tracks on a Router Stand

### STEP 12R

Position the outer track parallel to the inner track approximately 28" away from it. Place the table onto the tracks with the Inner Bearings (6) on the inner track. Always fit the table in this way. Slide the table to each end of its travel and adjust the position of the outer-track. The lengthened outer bearings make this a non-critical adjustment.

### STEP 13R

Adjust the height of the outer track until the fence is level, and parallel to the Router Table.

Check the sliding table throughout its travel for diagonal rocking on the tracks, and fine tune the height of the outer track if necessary. Adjust the height stops on the outer track legs to lock-in the correct height.

Next it will be necessary to fine-tune the height of the inner track. With a Router Table fitted, locate the fence onto the sliding table and extend it across the Router Table. The fence should sit around  $\frac{1}{32}$ " above the Router Table. Slide the table to the rear of the Stand and check it is level throughout the range. If necessary remove the inner track from the track clamps and relocate the shims, combining them or removing them entirely if required, at the front and/or rear. Loosely re-fit the bolts and nuts.

#### STEP 14R

With the sliding table positioned midway along the tracks, engage the front and rear locking latches (Fig. 10). Adjust the Phillips screws until the heads enter the slots and the table cannot be lifted. (You will need to release the latches and lift the table to make these adjustments).

#### STEP 15R

The last step is to fine-tune the inner track position in the horizontal plane. While this is not a critical alignment for routing, it is recommended.

The inner track can be aligned for the scales to read accurately only when used with the Router Table model RTA300. Fit a  $\frac{1}{2}$ " straight cutter into your router and find a parallel sided board, say 16" wide. In the 'Table Locked' mode, lock the rip fence at the exact board width (A). (Fig. 12). Place the board between the fence and the tip of the cutter then adjust the position of the inner track, (Fig. 11), until the board fits exactly between the fence and the blade and is parallel to the right hand edge of the router table, as shown. Tighten the Nyloc nuts.

For early model router and jigsaw tables lock the rip fence parallel in the 'Table Locked' mode, and measure from the face of the fence to the right hand edge of the Router Table (B). (Fig. 12). Adjust the inner track, (Fig. 11), until the fence is parallel to the edge of the table. Tighten the Nyloc nuts.

Your Sliding Extension Table is now fully assembled and ready for use. Skip to the 'Use with a Router Table' section.

## USE WITH A WORKCENTRE OR COMPACT

### - TABLE LOCKED

Lock the table using the front and rear locking latches and fit the rip fence. Set your width by sighting the scales down the front face of the fence. Ensure the fence is always set parallel to the blade (ie. locked at the same scale reading front and rear). (Fig. 13).

Make sure that the overhead guard is lowered onto the workpiece. Guide the sheet against the fence at all times. When working with long sheets the plastic skids at the ends of the inner track will provide additional support. However when handling very wide workpieces we recommend the Triton Multi-Stands (Fig. 14) or have someone assist you to support the workpiece. When ripping thin workpieces you may need to fit an edge support (as shown in the inset on Fig. 14) against the rip fence, to prevent the corner of the workpiece from dipping into the table openings.

MK3 Workcentres: to rip in the 10" - 15" range, clamp a 4' long x 8" wide packer to the extension table fence. When setting the required width, remember to add 8".

### TABLE SLIDING

Always slide the extension table the full length of the tracks before making your cut. Check that the rip fence clears the blade, and does not hit or 'ride up' on the table. Check that the sliding table does not rock on its tracks. Adjust the outer track height if necessary.

### Crosscutting

Position the rip fence as shown in (Fig. 15). When tightening the clamps, ensure that the fence is pulled fully toward the outer edge of the table, for absolute squareness.

For gauging lengths in the range  $14\frac{3}{4}$ " - 41", you can align the end of the workpiece with the required scale reading. For longer pieces, touch the fence tip against the saw blade teeth and use this to align a cutting mark on the workpiece. Note: if you wish to prevent the gradual cutting away of the fence tips (which were designed for this purpose) attach a small wooden fence tip using the screw holes provided.

## Panel Saw

This position provides a cutting capacity of up to 24" or more, depending on your saw size.

Position the fence as shown in (Fig. 16), ensuring it is pushed fully toward the outer edge of the table before tightening the clamps, for absolute squareness.

## Mitre Cutting

Mitres can be cut with the fence set at a trailing angle (Fig. 17) or leading angle (Fig. 18) and with the workpiece in front (Fig. 17) or behind the fence. (Fig. 18)

You can use the protractor to set the required mitre angle. Place it in the protractor slot as shown in (Fig.18). Align the extension table fence to the protractor in the position which best suits your workpiece, then remove the protractor.

## Taper Ripping

For slight tapers on large workpieces (ie. a small door), set the extension table fence to Panel Saw mode and insert a packer against it, as shown in (Fig. 19).

Tapers can also be cut by angling the rip fence. (Fig. 20) The required angle can be achieved by using the protractor as outlined in Mitre Cutting (Fig. 18). A parallel sided packer will be required to offset the distance between the fence and the protractor in establishing the correct taper angle.

Use G-clamps or similar to secure your work to the sliding table when taper ripping.

## USE WITH A ROUTER TABLE

Trenching, edge planing and shaping can be performed in all modes of operation with a Triton Router Table, either fitted to a Workcentre or a Router Stand (model RSA300 only).

## Edge Planing

For edge planing pieces up to 39" wide, any length, use the Fixed Table position (Fig. 21).

Set the extension table fence to the required width by measuring the distance from the router cutter to the fence, or by performing a test cut.

On earlier model Router and Jigsaw Tables set the rear section of the router table fence flush with

the router cutter and set the front sub-fence to the maximum depth of cut.

If using the Router Table model RTA300, remove the fence and fit the guard to the tabletop. The extension table scales can be used to plane accurately to width if using the same router bit used in fine-tuning the inner track on a Router Stand - Step 15R. If fitted to a Workcentre the scales can be adjusted to read true by following Step 15R. Remember to reset it back for saw use when finished routing.

Always guide your work along the extension table fence, not the router fence.

For planing edges up to 27½" long, you can use the sliding table mode with the extension table fence positioned as shown in Fig. 22. Use the extension table fence to align the workpiece, and set the router fence, if fitted, clear of the work.

## Trenching

Trenching is possible in all modes of operation. In the Table Sliding mode clamp a wooden batten to extension table fence and extend it past the cutter, as shown in Fig. 23. Run the batten through the cutter to create a sighting notch and to prevent tear-out in your workpiece.

For trenches up to 27½" long in the Table Sliding mode fit the extension table fence in the leading position (furthest away from you), as shown in Fig. 22. Longer trenches can be performed in the Table Locked mode (Fig. 21).

Always use extreme care if using the Router Table without the guard.

For large, awkward objects (eg. heavy staircase stringers) it may be necessary to use the router 'hand-held' against a guide clamped to the workpiece.

## GUARANTEE

To register your guarantee visit our web site at [www.tritontools.com](http://www.tritontools.com)\* and enter your details.

Your details will be included on our mailing list (unless indicated otherwise) for information on future releases. Details provided will not be made available to any third party.

## PURCHASE RECORD

Date of Purchase: \_\_\_ / \_\_\_ / \_\_\_\_

Model: ETA100

Retain your receipt as proof of purchase

Triton Precision Power Tools guarantees to the purchaser of this product that if any part proves to be defective due to faulty materials or workmanship within 12 MONTHS from the date of original purchase, Triton will repair, or at its discretion replace, the faulty part free of charge.

This guarantee does not apply to commercial use nor does it extend to normal wear and tear or damage as a result of accident, abuse or misuse.

\* Register online within 30 days.

Terms & conditions apply.

This does not affect your statutory rights